

## On the Design of the Latch Mechanism for Wafer Containers in a SMIF Environment

Jyh-Jone Lee, Dar-Zen Chen\*, Wei-Ming Pai

*Department of Mechanical Engineering, National Taiwan University,  
Taipei, Taiwan 10660 R.O.C.*

Tzong-Ming Wu

*Industrial Technology Research Institute, Hsinchu,  
Taiwan 310 R.O.C.*

This paper presents the design of a latch mechanism for wafer containers in a standard mechanical interface environment. For an integrated circuits fabrication factory, the standard mechanical interfaced wafer container is an effective tool to prevent wafers from particle contamination during wafer storage, transporting or transferring. The latch mechanism inside the container door is used to latch and further seal the wafer container for safety and air quality. Kinematic characteristics of the mechanism are established by analyzing the required functions of the mechanisms. Based on these characteristics, a methodology for enumerating feasible latch mechanisms is developed. New mechanisms with one degree-of-freedom and up to five links are generated. An optimum design is also identified with respect to the criteria pertinent to the application. The computer-aided simulation is also built to verify the design.

**Key Words :** Latch Mechanism, SMIF Environment, Kinematic Characteristics

### 1. Introduction

Control of particle contamination is imperative for cost effective and profitable manufacturing of integrated circuits (ICs). To minimize the possibility of particle contamination during manufacturing process, semiconductor wafers must be effectively isolated from their ambient environment for storage and transferring in the factory. To achieve this, the Standard Mechanical Interface (SMIF) technology (Parikh and Kacmpf, 1984; Doche, 1990; Book of SEMI standards, SEMI E19-0697; E62-0999.) has been developed

for the application, where a wafer container with no internal source of particle is utilized to store and transfer wafers during the manufacturing process.

Figure 1 shows the schematic of the wafer container (Bonora and Ocn, 1996). As the wafer container is mated to the port of processing equipment, an actuating device is engaged with the container door to release the latch mechanism. The container door with wafers in a cassette is then loaded into the processing equipment (Fig. 1(a)). After the manufacturing process is completed, a reverse operation takes place and the processed wafers are placed back into the wafer container. Design of the latch mechanism for the wafer container is significant, since the door of the wafer container provides a standardized input and output interface while engaging with the port of processing equipment. Any failure of the latch mechanism may result in serious malfunctions for subsequent operation procedure. This may affect

---

\* Corresponding Author.  
E-mail : jjlee@nu.edu.tw  
Department of Mechanical Engineering, National Taiwan University, Taipei, Taiwan 10660 R.O.C. (Manuscript Received November 17, 2005; Revised September 19, 2006)

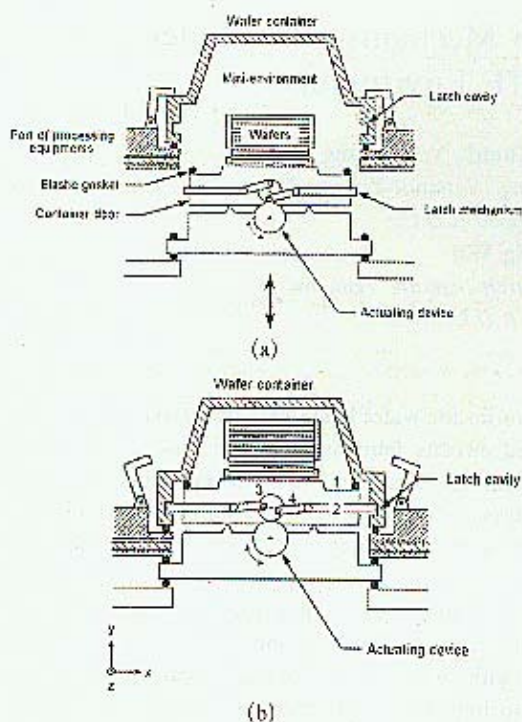

Fig. 1 SMIF environment: (a) Unlatched status; (b) Latched status

loading and unloading wafer and even cause damage of wafers. A number of latch mechanism designs have been proposed and patented (Bonora and Oen, 1996; Maney et al., 1987; Muka et al., 1997a; 1997b; Muka, 1997; 1998; Nyseth, 1998; Hosoi, 1998; Bonora and Rosenquist, 1991; Bonora et al., 1998; Murata et al., 1998; ; Fan et al., 1999; Mikkelsen et al., 1999). Figure 1(b) shows a specific design which employs a linkage-type mechanism. While operating, a rotary actuating device activates the input link of the mechanism (link 3). Then, the latch link (link 2) is driven into the latch cavity of the container lid and latches the door. It can be seen that this type of mechanism provides only latching function without air-tightening the door with the container. Some other designs provide not only the latching function but also the sealing effect of the door. Figure 2 (Bonora and Rosenquist, 1991) shows such a design. In the figure, an input (link 3) is pin-jointed to the door case. A rotary actuating

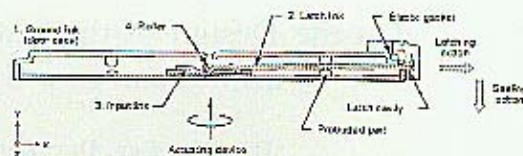

Fig. 2 A latch mechanism design (Bonora and Rosenquist, 1991)

device is applied to drive the input link to rotate about the vertical axis  $y$ . A roller, pin-jointed to one end of the latch link 2 is paired with the input link via a cam pair. Hence, when the input link is driven to push roller in the direction  $x$ , the cam lobe on the input link also up-moves the latch link in the direction  $y$ . The movement of the roller in the direction  $x$  allows the latch link to slide into the latch cavity and latches the container door. The upward movement causes the latch link to tip over the protruded part in door and yields the other side a downward action on the rim of the latch cavity. This downward action deforms the elastic gasket arranged on the peripheral of the container door and hence results in an airtight effect of the wafer container. In summary, the general design task of the latch mechanism can be carried out based upon some guidelines as described in Table 1. The sealing effect has been emphasized in recent years since the air quality in the container can thus be controlled by introducing a relatively inert gas, such as dry nitrogen or dry air.

Up to date, the design of such mechanisms is performed based upon designer's ingenuity and experience. The objective of this work is to develop a systematic methodology through which the latch mechanism can be designed and simulated. Performance characteristics of various designs can be evaluated and compared in order to reach an optimum design based upon some specific design requirements. In what follows, we shall review the functional requirements of the mechanism followed by a summary of the structural characteristics of such device. Then, a systematic method with the aid of graph theory is conducted to generate acceptable latch mechanisms and an optimum design is identified with respect to some prespecified criteria. Finally, a computer-aided

**Table 1** Table 1 General design guidelines for wafer container

1	<p>Regulation of standards</p> <p>Specifications for semiconductor processing equipment have been standardized in the recent decades. Design of the wafer container has to cope with the industrial standards, mainly the Semiconductor Equipment and Materials International (SEMI) standards E19-0697 and E62-0999 (Book of SEMI standards, SEMI).</p>
2	<p>Reliability</p> <p>The latch mechanism is a crucial component for the standardized input/output interface of the wafer container. Any mechanical failure may result in serious malfunctions for subsequent operation and causes damage of wafers and economical losses. Thus, the reliability issue should be greatly attended in the design.</p>
3	<p>Resistance to abrasion</p> <p>Internal sources of particles inside the wafer container will directly expose to and contaminate wafers. The latch mechanism is expected to contain minimal wear among parts to prevent from generating articles while operating.</p>
4	<p>Air-tightness</p> <p>Due to the increasingly sophisticated manufacturing process, wafers are required to store in an environment of high air quality. Containers with air-tightness are able to provide a better control of air quality.</p>

design and simulation is performed to evaluate and verify the functions that were set prior to the design.

## 2. Functional and Structural Considerations of the Latch Mechanism

Once a designer sets specifications of a latch mechanism, effective design processes such as conceptual design and function verification need to be established. These processes are usually cross-dependent and recursive, for example, the dimensional restrict may be crucial while evaluating various kinematic structures. In this section, the functional considerations for the latch mechanism during the conceptual design phase will be first analyzed from the kinematic point of view. This can help us clarify the design goal and simplify the procedure for mechanism creation. As described previously, our goal is to determine the mechanism with functions of latching as well as sealing after the container door is engaged with the lid. It can be noted that the two functions need to work independently of each other to provide sequential motions. The problems we now have are that the input motion, obliged to comply with

the industrial standards as SEMI standards (Book of SEMI standards, SEMI E19-0697; E62-0999), and the output motion required by functional specification are not in the same plane. It appears that the mechanism is in three dimensions. However, we believe that plane mechanism can be used to perform the desired motions if appropriate assumptions are made. We first observe that the input and output links have the following motion characteristics.

**CH 1.** Relative to the container door (frame), the input link should produce a rotary motion about the direction of door engaging/disengaging ( $y$ -axis). This motion characteristic is raised by the external industrial standards as described in (Book of SEMI standards, SEMI E19-0697).

**CH 2.** Relative to the container (frame), the latch link should be able to move in a plane that is made up of the latch motion ( $x$ ) and the sealing motion ( $y$ ).

These two characteristics describe the motion features of the input and output links with respect to the mechanism frame door case. Moreover, it is reasonable to assume that the input and output links are directly adjacent to the frame so that floating members in the design can be avoided. Therefore, a kinematic chain, called functional

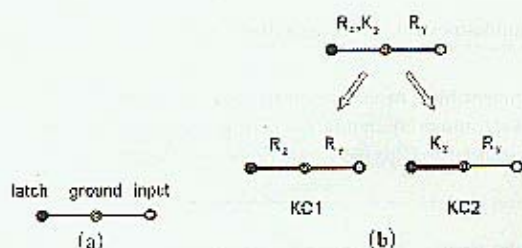

Fig. 3 (a) A kinematic chain of latch-ground-input link; (b) Admissible functional kinematic chains

kinematic chain (Fig. 3(a)) can be developed to describe the relationship among the three links: input, output, and frame. In Fig. 3(a), the graph is used to represent the mechanism where links are denoted by vertices and kinematic pairs by edges. The functional kinematic chain can be further realized by specifying kinematic pairs between two adjacent links. As required by CH 1, the motion of the input link can only be achieved by specifying a revolute kinematic pair rotating about the  $y$ -axis. In a similar manner, as required by CH 2, the motion of the latch link can be achieved by specifying a revolute kinematic pair rotating about the  $z$ -axis or a plane cam pair moving on the  $x$ - $y$  plane. As a consequence, two types of functional kinematic chain, KC 1 and KC 2 can be constructed as shown in Fig.3(b). Here, the kinematic pairs are also labeled according to their type such as  $R$  for revolute pair,  $P$  for prismatic pair and  $K$  for cam pair. The subscript under  $R$ ,  $P$ ,  $K$ , respectively indicates the rotating axis of  $R$ , the direction of motion of  $P$ , and the direction perpendicular to the cam motion plane. Note that the motion characteristic and the structural characteristic of the latch mechanism have been implemented in the functional kinematic chain. Mechanisms that comprise the functional kinematic chain can thus produce the motions specified in the functional requirement.

### 3. Mechanism Creation Using Graph Theory

Graph theory has been applied to the mechanism design in a variety of industrial application.

One of the advantages of using graph theory for mechanism design is that it may provide a systematic procedure for enumerating new mechanisms (Buchsbbaum and Freudenstein, 1970; Dobrjanskyj and Freudenstein, 1967; Woo, 1967; Freudenstein and Maki, 1979; 1983; 1984; Datsoris and Palm, 1985; Erdman and Bowen, 1981). In the traditional approach for creating new mechanisms using graph theory, the procedure is conducted by (Yan, 1992; Tsai, 2000): (1) generating feasible graphs according to the number of degree of freedom and/or number of links/joints; (2) labeling the feasible graphs with a given set of joint types, and identifying the fixed, input, and output links as needed; and (3) evaluating functional feasibility from the labeled graphs to yield optimum solution(s). However, a disadvantage of the procedure is that the enumeration in Step 2 is inefficient and the number of mechanisms obtained by this process is usually enormous. In what follows, a more efficient process is proposed. In the process, an intermediate step which uses the functional kinematic chain as a prespecified requirement for identifying feasible graphs is applied between the first and second step. This can effectively reduce undesired mechanisms that will not be necessarily proceeded for further evaluation. The enumeration procedure is summarized as follows:

Step 1. Search for feasible kinematic structures of the mechanism.

The feasible kinematic structures for the mechanism can be identified from the available atlases of graphs (Mayourian and Freudenstein, 1984). The requirements of feasible kinematic structures are determined according to number of degree of freedom, number of links, and permissible types of kinematic pairs. Details of derivation are listed in the Appendix 1. By using these requirements, the results are listed in Table 2, where kinematic pairs of 1-DOF are denoted by thin edges and those of 2-DOF are by thick edges.

Step 2. Identify functional kinematic chain.

In this step, the feasible kinematic structures found in Step 1 are further examined such that they contain the functional kinematic chains KC

**Table 2** Kinematic structures with up to 5 links (Buchsbaum and Freudenstein, 1970; 32)

(n, J)	Graphs of kinematic structures
(3, 3)	
(4, 4)	
(4, 5)	 (1)                      (2)
(5, 6)	 (3)

I or KC 2.

Detail rules are summarized in the Appendix 2. This process can efficiently reduce other possibility for generating irrelevant mechanisms since functional requirements of the mechanism are embedded in the functional kinematic chain. Three feasible kinematic structures containing functional kinematic chain KC 1 and two feasible kinematic structures containing functional kinematic chain KC 2 can be identified and are respectively shown in the Table 3(a) and 3(b).

**Step 3. Label the remaining joints**

For the kinematic structures with identified functioning kinematic chain shown in Table 3, the remaining unlabeled joints can be labeled according to the structural characteristics of the functional kinematic chain. For example, links in the same loop with the latch link are necessarily confined to move in *x-y* plane, and thus, those thin edges in the loop can be labeled as revolute pairs with the joint axis directing along *z* axis or prismatic pair sliding on *x-y* plane, and those thick edges are labeled as cam pairs with the plane of motion parallel to *x-y* plane. Details of the labeling rules are also listed in Appendix 3. In this scheme, enumerated mechanisms with kine-

**Table 3(a)** Feasible latch mechanisms with KC 1

Identification of KC 1	Feasible latch mechanisms

**Table 3(b)** Feasible latch mechanisms with KC 2

Identification of KC 2	Feasible latch mechanisms

matic chain KC 1 are shown in Table 3(a). There are nine mechanisms included in this classification. The double subscript under P represents an arbitrary direction of motion on the said plane. Figure 4(a) also shows the function schematics of Case 1, 2, and 6. In general, the latch link, pinned to the frame, can generate both latching and sealing functions when driven by its preceding sliding block. Similarly, enumerated mechanisms with kinematic chain KC 2 are shown in Table 3(b). There are ten mechanisms included in this classification. The functional schematics of case 1 and case 3 are also shown in Fig. 4(b). Unlike the mechanisms with the functional kinematic chain, KC 1, the latch link is paired with the frame by a pin-in-slot joint which may provide a more versatile motion for the latch link as

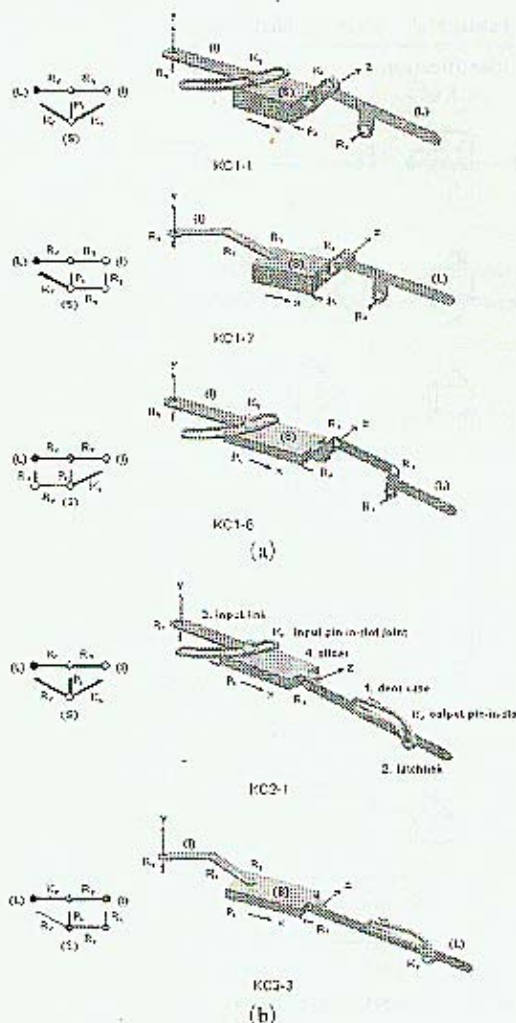

Fig. 4 Functional representations of feasible latch mechanisms: (a) KC 1-1, KC 1-2 and KC 1-6; (b) KC 2-1 and KC 2-3

will be discussed in the following section.

#### 4. Optimum Mechanism Design

The selection for optimum mechanisms among the set of 19 mechanisms shown can be performed by determining how well the functional criteria are satisfied. In Fig. 4(a) and 4(b), cases for the latch link connecting the frame with revolute pair are rejected, since a translation output is not directly available in the mechanism. Thus all the

cases in KC 1 group are rejected. Mechanisms with four links are preferred to those with five links, due to strict dimensional limit in the door. Case KC 2-1 is better than case KC 2-2 since mechanism KC 2-2 has one more sliding pair than KC 2-1. This may increase the possibility of abrading between the two sliding links and result in particle generation after a long period of operation.

Configuration KC 2-1 is optimum, since the slider can be driven by the input link for any specified motion via the input pin-in-slot joint. Also, the latch link driven by the slider can move properly once the output pin-in-slot joint is well designed.

#### 5. Enhancements of Mechanism for Latching and Sealing Action

The output pin-in-slot joint formed at the latch link and the frame can affect the output motion of the latch link. We recall that the latching and sealing actions should be performed independently and sequentially. Design of the output cam slot can be performed as follows. As shown in Fig. 5(a), the latch link is to slide from an initial position  $A$  to position  $A'$  by a distance  $m$  during the latching action. Therefore, a straight slot can be selected for this section of the cam slot such that pivot  $P$  of the latch link is guided to move to position  $P'$ . Followed by latching, while one end of the link  $P'$  moves in the cam slot, the latch link will pivot about  $B$  and move the other tip  $A$  from  $A'$  to  $A''$  by a distance  $h$ . Locus of the curve from  $P'$  to  $P''$  during this motion can be determined by the relationship as

$$X = (L_1 + L_2) (1 - \cos \theta) \quad (1)$$

$$Y = -L_1 \sin \theta \quad (2)$$

where  $L_1$  is the length between  $P''$  and  $B$ ,  $L_2$  is the length between  $B$  and  $A''$ , and  $\theta = \sin^{-1}(h/L_2)$ .

We assume that the latch link should contain two independent motions as latching and sealing. This goal has been attained, but the designed mechanism has to be examined in view of total functions. A solid model (Fig. 6) as well as mock-

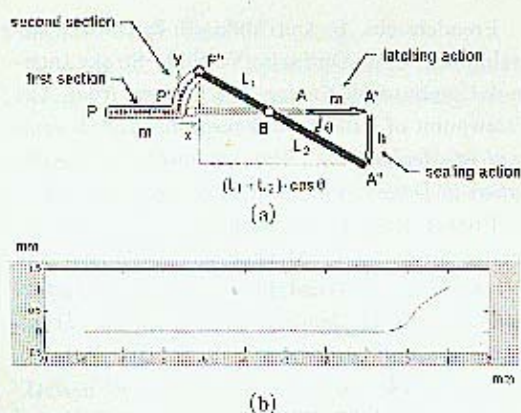

Fig. 5 (a) Output cam slot ; (b) A numerical example

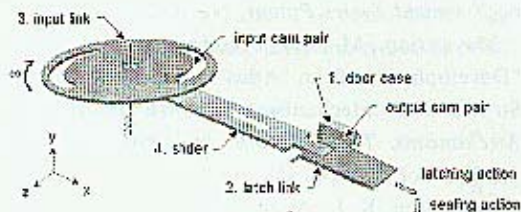

Fig. 6 Solid model of KC 2-1

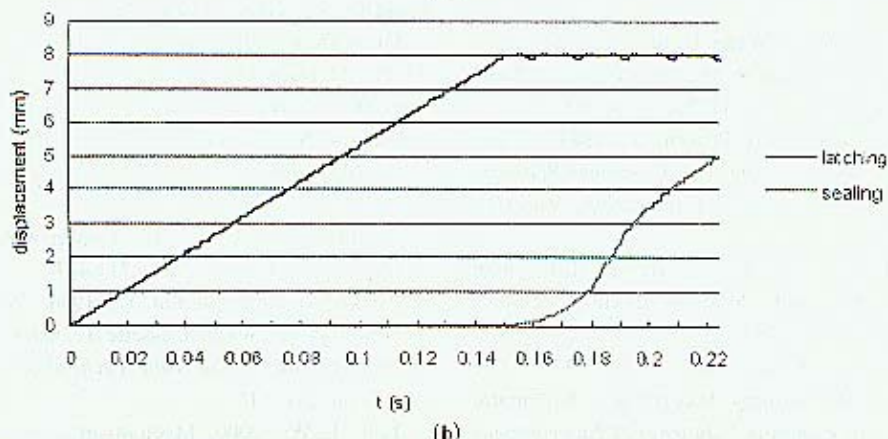
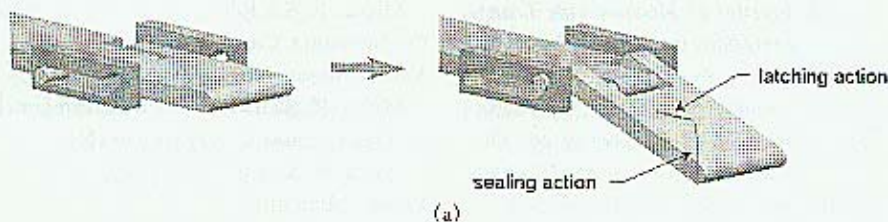

Fig. 7 (a) Motion of the latch link ; (b) Displacements of the latching and sealing actions

up has been built to verify this mechanism. Figure 7(a) shows the simulation of trajectory of the latch link tip. Fig. 7(b) also shows the  $x$  displacement curve of the latch link tip. From the figure, it is seen that the latching action (motion in  $x$  direction) and the sealing action (motion in  $y$  direction) work independently.

### 6. Conclusions

A methodology has been developed for designing the latch mechanism which is used in a wafer container. The method is based on functional and structural considerations which ensure a systematic and efficient procedure to enumerate all potentially acceptable mechanisms. Among those acceptable mechanisms, an optimum design is identified with respect to specified criteria. It is concluded from this work that effective and novel mechanisms can be achieved.

### Acknowledgments

The financial support of the National Science

Council (NSC-91-2212-B-002-083) of Taiwan is gratefully appreciated.

## References

- Bonora, A. C. and Oen, J. T., 1996, "Direct Loadlock Interface," *United States Patent*, No. 5,586,585.
- Bonora, A. C. and Rosenquist, F. T., 1991, "Sealable Transportable Container Having Improved Latch Mechanism," *United States Patent*, No. 4,995,430.
- Bonora, A. C., Rosenquist, F. T. and Jain, S., Davis, M. R., 1998, "Sealable, Transportable Container Having a Breather Assembly," *United States Patent*, No. 5,740,845.
- Book of SEMI standards, SEMI E19-0697.
- Book of SEMI standards, SEMI E62-0999.
- Buchsbaum, F. and Freudenstein, F., 1970, "Synthesis of Kinematic Structure of Geared Kinematic Chains and Other Mechanisms," *Mechanism and Machine Theory*, Vol. 5, pp. 357~392.
- Daisiris, P. and Palm, W., 1985, "Principles on the Development of Mechanical Hands Which Can Manipulate Objects by Means of Active Control," *ASME Journal of Mechanisms, Transmissions, and Automation in Design*, Vol. 107, No. 2, pp. 148~156.
- Dohrajskyj, L. and Freudenstein, F., 1967, "Some Applications of Graph Theory to The Structural Analysis of Mechanisms," *ASME Journal of Engineering for Industry*, Vol. 89, pp. 153~158.
- Doche, C., 1990, "Wafer Confinement for Control of Contamination in Microelectronics," *Solid State Technology*, Vol. 33, No. 8, pp. S1~S5.
- Erdman, A. G. and Bowen, J., 1981, "Type and Dimensional Synthesis of Casement Window Mechanism," *Mechanical Engineering*, Vol. 103, pp. 46~55.
- Fan, H. K., Lee, J. J. and Huang, G. J., 1999, "Latch Mechanism for Wafer Container," *United States Patent*, No. 5,931,512.
- Freudenstein, F. and Maki, E. R., 1979, "The Creation of Mechanisms According to Kinematic Structure and Function," *Journal of Environment and Planning*, Vol. 6, pp. 375~391.
- Freudenstein, F. and Maki, E. R., 1983, "Development of an Optimum Variable-Stroke Internal-Combustion Engine Mechanism from The Viewpoint of Kinematic Structure," *ASME Journal of Mechanisms, Transmissions, and Automation in Design*, Vol. 105, No. 2, pp. 259~267.
- Freudenstein, F. and Maki, E. R., 1984, "Kinematic Structure of Mechanisms for Fixed and Variable-Stroke Axial-Piston Reciprocating Machines," *ASME Journal of Mechanisms, Transmissions, and Automation in Design*, Vol. 106, pp. 355~364.
- Hosoi, M., 1998, "Shipping Container," *United States Patent*, No. 5,988,392.
- Mancey, G. A., O'Sullivan, A. W. and Faraco, W. G., 1987, "Sealed Standard Interface Apparatus," *United States Patent*, No. 4,674,939.
- Mayourian, M. and Freudenstein, F., 1984, "Development of an Atlas of The Kinematic Structures of Mechanisms," *ASME Journal of Mechanisms, Transmissions, and Automation in Design*, Vol. 106, pp. 458~461.
- Mikkelsen, K. J., Adams, M. S., Bores, G. and Wiseman, B. S., 1999, "Wafer Enclosure with Door," *United States Patent*, No. 5,957,292.
- Muka, R. S., 1997, "Door Drive Mechanisms for Substrate Carrier and Load Lock," *United States Patent*, No. 5,609,459.
- Muka, R. S., 1998, "Vacuum Integrated SMIF System," *United States Patent*, No. 5,752,796.
- Muka, R. S., Pippins, M. W. and Drew, M. A., 1997a, "Batchloader for Substrate Carrier on Load Lock," *United States Patent*, No. 5,607,276.
- Muka, R. S., Pippins, M. W. and Drew, M. A., 1997b, "Cluster Tool Batchloader of Substrate Carrier," *United States Patent*, No. 5,613,821.
- Murata, M., Tanaka, T. and Morita, T., 1998, "Sealable Container," *United States Patent*, No. 5,743,424.
- Nyseth, D. L., 1998, "Wafer Carrier with Door," *United States Patent*, No. 5,711,427.
- Parikh, M. and Kaempf, U., 1984, "SMIF: A Technology for Wafer Cassette Transfer in VLSI Manufacturing," *Solid State Technology*, Vol. 27, No. 7, pp. 111~115.
- Tsai, L. W., 2000, Mechanism Design: Enumeration of Kinematic Structure According to



Function, CRC Press, New York.

Woo, L. S., 1967, "Type Synthesis of Plane Linkages," *ASME Journal of Engineering for Industry*, Vol. 89, pp. 159~172.

Yuo, H. S., 1992, "A Methodology for Creative Mechanism Design," *Mechanism and Machine Theory*, Vol. 27, No. 3, pp. 235~242.

### Appendix 1: Derivation for Feasible Kinematic Structures

Design of the latch mechanism is limited to planar mechanisms of one degree-of-freedom. For the sake of simplicity in engineering design, we also limit the link number up to five links and all kinematic pairs to be revolute ( $R$ ), prismatic ( $P$ ), or planar cam pairs. The equation for the degree of freedom of the mechanism can be written as

$$F=3(n-1)-2j_1-j_2 \quad (A1)$$

$$J=j_1+j_2 \quad (A2)$$

where  $F=1$  is the DOF,  $n$  the link number,  $j$  the number of joints, and  $j_i$  the number of  $i$ -DOF joints. Solving for  $(n, j_1, j_2)$ , yields  $(n, j_1, j_2) = (3, 2, 1)$  or  $(4, 4, 0)$  or  $(4, 3, 2)$ .

### Appendix 2: Rules for Finding Feasible Graphs that Contain Functional Kinematic Chain

(1) Since links in the same loop of a planar mechanism move in the same plane, the latch link

(moving in  $xy$  plane) and input link (moving in  $xz$  plane) must be placed in different loops.

(2) The common links between the two loops shall slide along the intersection of the  $xy$  and  $xz$  planes, i.e.  $x$  axis, and hence, the joints connecting the common links should be specified as prismatic joints moving in  $x$  direction. Note that only one such common joint is allowed in order to avoid two prismatic joints adjacent to each other.

### Appendix 3: Rules for Labeling Kinematic Pairs for Feasible Graphs

(1) Links in the same loop with the latch link are confined to move in the same plane, i.e.  $xy$  plane. Thus, unspecified thin edges in this loop can be labeled as revolute joints with the rotating axis about  $z$ -axis ( $R_z$ ) or prismatic joints in arbitrary directions on  $xy$  plane ( $P_{xy}$ ), and unspecified heavy edges in this loop can be labeled as planar cam pairs with the rotating axis about  $z$ -axis ( $K_z$ ).

(2) Links in the same loop with the input link are confined to  $xz$  plane. Thus, unspecified thin edges in this loop can be labeled as revolute joints with the rotating axis about  $y$ -axis ( $R_y$ ) or prismatic joints in arbitrary directions on  $xz$  plane ( $P_{xz}$ ), and unspecified heavy edges in this loop can be labeled as planar cam pairs with the rotating axis about  $y$ -axis ( $K_y$ ).

(3) The common joint between the two loops can be labeled as prismatic joint with the sliding motion along  $x$  direction ( $P_x$ ).